



## ASSEMBLING OF THE “BOLT” CREEDMOOR SIGHT USA 418 ON THE M.86/71 LEVER ACTION RIFLE

The rifle is pre-fit to assemble the “Bolt” Creedmoor sight on the bolt #8 where the nut #2 is already fit, blocked by the screw #1. These two features are at the bolt rear side, in front of the hole (X) which is the seat of the Creedmoor sight elevation spring # 5.

The nut #2, tighten to the screw #1 does not interfere with the firing pin which is into the bolt. To assemble the Creedmoor sight #7 code USA 418 on the rifle, please follow the below instructions.

1. First of all, check whether the rifle is already pre-fit for this Creedmoor sight. The verification is possible if there are the two slots on the bolt (see picture 1a).



Picture 1a

2. Slightly untie the screw #1 without removing it. Using the Creedmoor sight back end like a wrench, insert it into the slots A (see picture 2a). In this way the nut #2 which has two squared sides will be driven into Creedmoor sight base #7 without rotating or moving (drawing 1).



Picture 2a

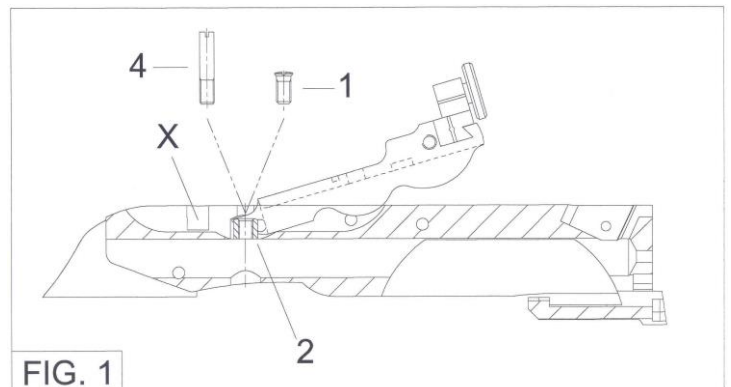

3. Untie completely the screw #1 (pictures 3a, 4a) and replace it with the threaded pin #4 that needs to be tightened, always keeping the base #7 in contact with the nut #2, such not to move it (picture 5a).



Picture 3a



Picture 4a



Picture 5a

4. Insert the spring #5 in its seat (drawing 2).

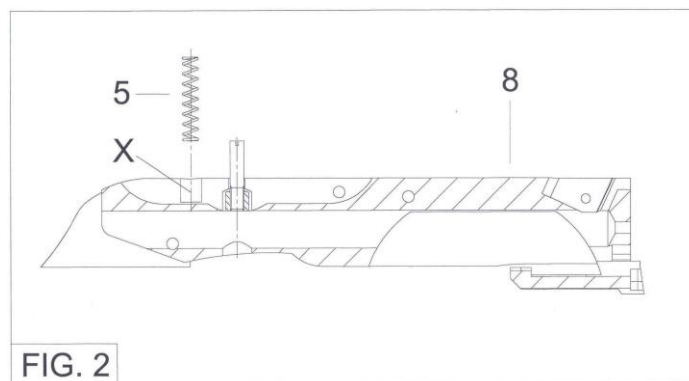
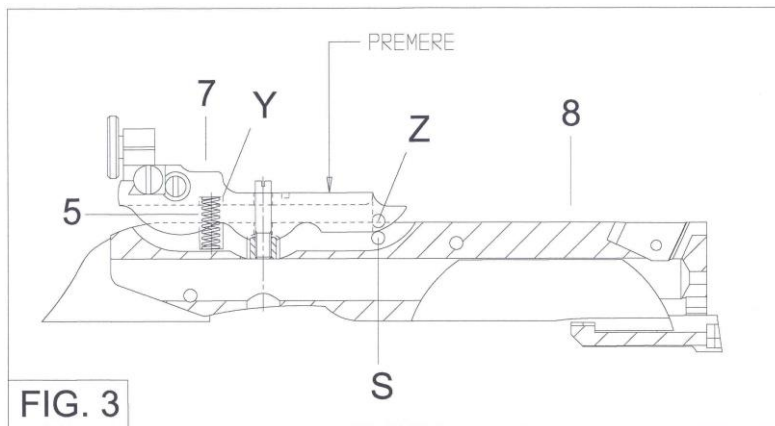
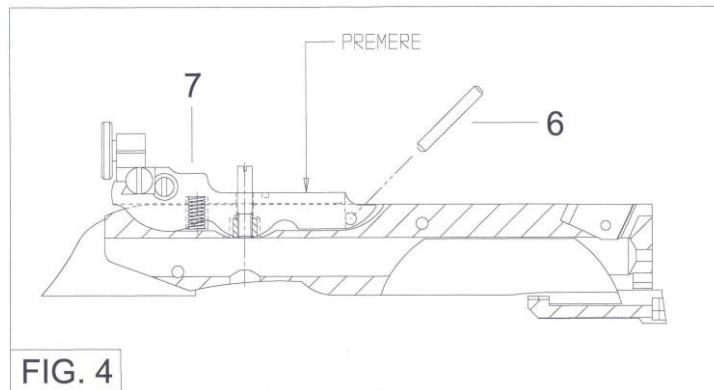

FIG. 2

5. Push the Creedmoor sight completely in, like shown in the (drawing 3), making sure that the spring #5 gets into the Creedmoor sight underneath hole (Y) and that the forward hinge hole (Z) is aligned with the bolt hinge hole (S). At this point the pin #4 will be well set into the Creedmoor sight and the bolt.



6. By pushing the Creedmoor sight front end the two hinged holes will be perfectly aligned to fit the pin # 6 (drawing 4).



7. Keeping the Creedmoor sight #7 pushed in its position, you can now remove the pin #4 replacing it with the adjusting screw #3, tightening it to the bottom (drawing 5).

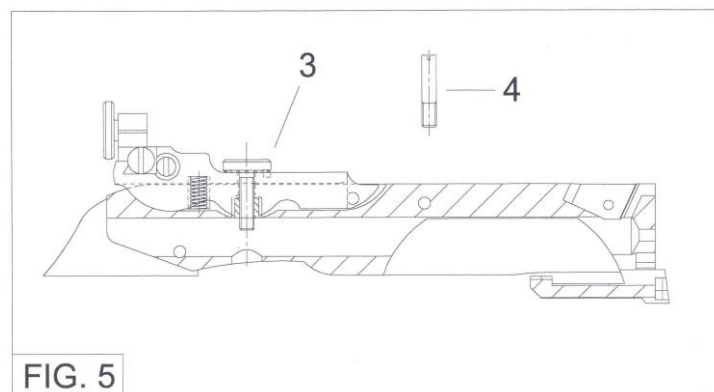

8. Replace the hinged pin #5 with the final hinge pin #9, which has to be end flat into the bolt (drawing 6).

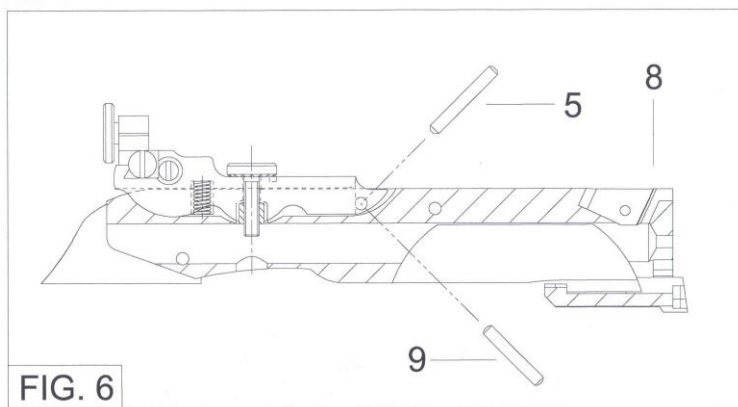

**WARNING: TO ASSEMBLE THE CREEDMOOR SIGHT USA 418 ON THE PEDERSOLI 1886/71 LEVER ACTION RIFLE, WE SUGGEST YOU TO ADDRESS TO A GUNSMITH.**