

FIG. 1
SETTING 1.25"

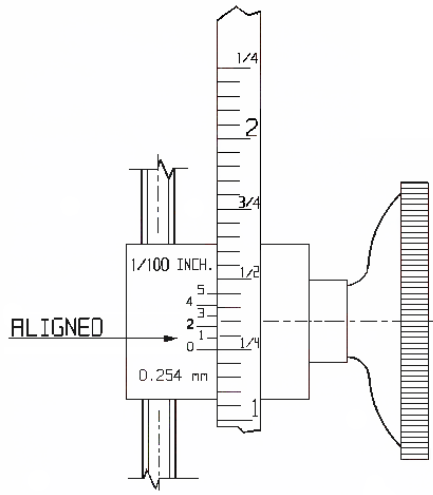

FIG. 2
SETTING 1.26"

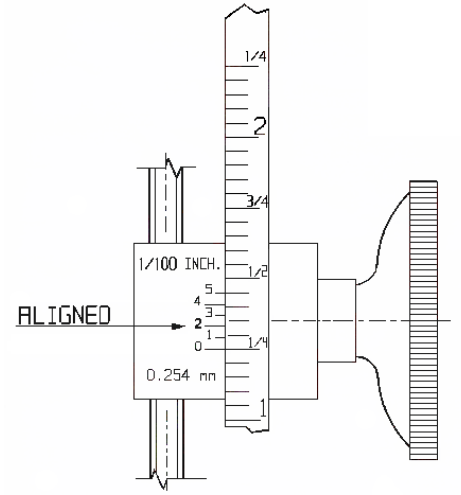
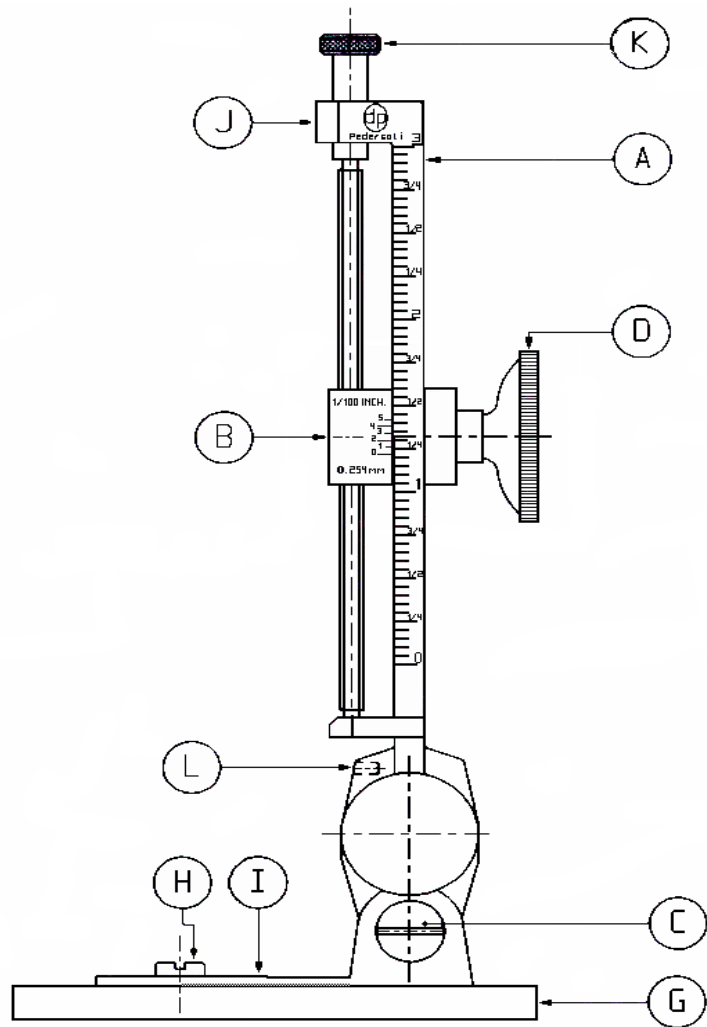
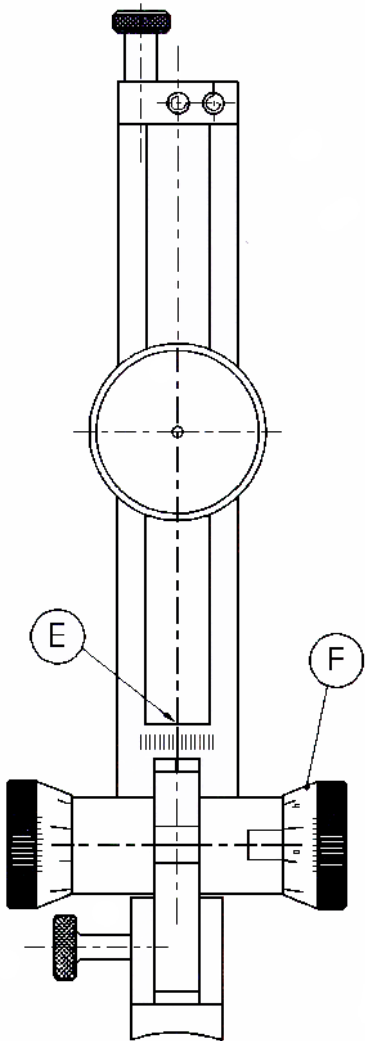

FIG. 3
SETTING 1.27"





PEDERSOLI DAVIDE & C. S.n.c.

25063 GARDONE V.T. (BS) – ITALY

Via Artigiani, 57 – P.O. Box 150

Tel. 030.8915000 – Fax 030.8911019

info@davidepedersoli.com - www.davide-pedersoli.com



CREEDMOOR SIGHTS

MOD. USA 404 – USA 405 – USA 406

INSTALLATION ON YOUR RIFLE

Your Pedersoli mid range or long range Soule tang sight is provided with three mounting holes in the base plate (G). The nominal centers are 2.25" apart and will fit all Pedersoli built replica rifles.

The front hole is elongated to allow fitting to other brands of rifles which may have a slightly different hole spacing. The center hole is for certain rifles which require a hole in that location.

Four sight mounting screws (two 10x28 and two 4 mm) are supplied for use on Pedersoli made rifles and these will fit the two tang holes originally plugged with slot head set screws. Note that the sight base (G) can be turned around and thereby will fit many other types of rifles because there are two detent notches in the bottom of the staff (A) and this increases the staff angle positions which will be available. It is important that the tang sight staff must stand vertically in relation to the action frame and barrel center line, both in side view as well as from a rear view.

This must be checked with a suitable carpenters or machinists bubble level. Mount the rifle in a padded bench vise and use the bubble level to position the breech sides vertically and the barrel horizontally (make allowance for barrel taper if necessary). Loosening (or removing) screw (H) will allow the spring (I) to be positioned back or forward until the staff (A) is vertical from a side view.

Tighten the screw firmly and apply a small amount of gun grease to the rear end of the spring where it engages the staff notch. When viewed from the rear it necessary to have the sight standing perfectly vertical and to position the staff vertically it may be necessary to insert suitable metal, hard paper or plastic shim material under one side or the other of the sight base, as necessary. Use the bubble level to verify that you have obtained good vertical positioning. When you are satisfied with the installation, tighten screw (C) to apply enough pressure on the pivot joint so that when the rifle is fired the staff assembly will tip forward a small amount. Avoid excessive tightening. For case extraction, loading and cleaning the sight is tipped backwards to allow a clear pathway into the barrel chamber.

Note the small socket head screw (L) located on the front face of the Soule body.

This screw holds the staff (A) in proper tight assembly with the Soule body and should not be removed or loosened.

USING THE ELEVATION SCALE

(It is necessary to loosen the eye cup (D) when making any adjustments. Use light to moderate pressure when retightening the eye cup). The staff (A) is marked with 20 lines per inch and each line equals .050" (see "Using Minutes of Angle & Sight Scales" chart for further data). With the popular 30" barrel length, each .010" of elevation change equals 1.0 Minute of Angle (MoA) and at 100 yards one MoA = 1.0" and at 200 yards one MoA = 2.0 " and so forth for other hundred yard increases in distance. Each .050" line therefore equals 5.0 MoA or 5.0" at 100 yards and 10.0" at 200 yards and so forth longer distances. The moveable vernier slider (B) has five lines .040" apart. This system allows you to change elevation in 1/100 of an inch (.01"). Fig. 1 shows the vernier zero line aligned with the 1 1/4" line (1.25"). Fig. 2 shows line # 1 of the vernier aligned with the first line above the 1.25" line. This adds .01 to the 1.25 making the reading 1.26". Fig 3 shows the second vernier line aligned with the second line above the 1.25" line and this adds .02" to the 1.25" setting making the reading 1.27".

This system is continued for the third and fourth line as well and they add .03" and .04" to the original 1.25" setting. When you align the #5 vernier line with the fifth line above the 1.25" line, you will see that the zero line has also been aligned with the next line above 1.25, thus making the setting 1.30" because you have increased the original 1.25" by .05".

Remember that each .010" changes bullet impact point by One MoA regardless of the shooting distance. Study the chart". Using Minutes of Angle & Sight Scales". Practice resetting your Soule sight as often as necessary. Soon you will be doing it quickly and correctly.

USING THE WINDAGE SCALE

The big advantage of the Soule type tang sight lies in it's ability to allow a shooter to quickly and accurately make windage changes called for by his or her "spotter" during a shooting match. Wind changes result in the bullet striking left or right of center. The spotter looking through a telescope calls out the amount of MoA needed to bring the shots back to center. As the wind rises and falls the spotter calls for repeated changes. Championship shooters use the Soule sight to make these changes quickly without need for magnifying glasses or having to closely examine fine lines on a windage scale. Hunters who have previously sighted in during windless conditions, can quickly apply the needed windage minutes of angle when wind comes up or goes away. Champion shooters world-wide use the Soule type sight for these reasons. It is simply the very best vernier tang sight you can own and use!

The moveable windage scale (E) has 8 lines left and right of center. Each line is .025" wide and represents 2.5 MoA at any distance. The Soule knob (F) has 5 numbers, 0 to 4, and when the knob is turned one full turn it will move scale (E) exactly 2.5 MoA. The space between each of the five numbers is equal to $\frac{1}{2}$ (0.5) MoA movement and if the setting is placed on the line between any two numbers this represents a $\frac{1}{4}$ (0.25) MoA movement. As an example of how this is used, let's say a shooter is competing with a steady wind coming from the right side and his spotter has called for 4.5 MoA of right side windage which brought the shots nicely into the center of the target. Suddenly, the wind dies out, so the spotter calls out, "bring windage back to zero center".

The shooter merely turns his Soule knob (F) quickly and returns scale (E) back to zero center.

When to wind again returns to the former condition, the shooter quickly turns the Soule knob clockwise one full turn plus 4 more marks, which equals 4.5 right side MoA again. When Soule knob (F) is turned clockwise (viewed from right side) this moves the bullet point of impact to the right on the target. Turning the Soule knob counter-clockwise moves bullet point of impact to the left on the target.

CARE AND MAINTENANCE

Your Pedersoli Mid-Range tang sight is a precision instrument and must be protected against being struck or bent. After each shooting session, carefully wipe it to remove possible cleaning liquids and dirt. Apply a thin film of gun oil to all exterior surfaces to prevent rust formation. Check the two screws (J) at the top of the staff assembly. If set too tight they will cause a bind on the main threaded screw. Adjust to obtain a slight drag when the elevation knob (K) is turned.

Because leather and trapped humidity can cause corrosion, we advise against storing the gun or sight in a leather case or a sealed container for an extended period of time.

USING MINUTES OF ANGLE (MOA) & SIGHT SCALES

The lines on the elevation and windage scales are used to change where your bullet will hit. The distance between the front and rear sight aiming apertures is called the "sight radius".

Measure this distance on your rifle and select from the list below, the distance which is close to your own sight radius

Distance between front and rear sights	Sight movement equals 1 MoA (Minute of Angle)
32 inch radius	.009"
34 inch radius	.010"
36 inch radius	.010"
38.75 inch radius	.011"

(The above numbers are rounded off to a practical amount and the two .010" numbers are correct)

HOW TO USE MINUTES OF ANGLE TO CHANGE POINT OF IMPACT

One MoA is approximately equal to 1.0 inch at 100 yards, 2.0 inches at 200 and so on, for longer distances. Use the "MoA in Inches" chart to see how one MoA changes at longer distances and remember that for your sight radius, the amount of sight movement needed for one MOA change remains the same for ALL DISTANCES.

Using the 30 inch barrel rifle having a sight radius of 34 inches as an example:

If the test target at 100 yards, shows bullets striking to the left of center by say 4 inches, you need to move the POI right by 4 MoA and this is $4 \times .010" = .040"$ on the windage scale. Move the Soule knob (F) one full turn (2.5 MoA) plus an additional 3 numbers (1.5 MoA) to obtain the needed .040" movement on scale (E)

Elevation changes work in a similar manner (see USING ELEVATION SCALE).

MINUTES OF ANGLE IN INCHES FOR VARIOUS DISTANCES

The data chart shown below is very useful when shooting in Silhouette or long range Creedmoor matches. All the needed distances are listed and the size of one MoA given, so your sight adjustments can be accurately made.

Yards	Meters	MoA	Yards	Meters	MoA
100	91	1.04	700	640	7.33
109	100	1.08	766	700	7.56
200	183	2.09	800	731	8.37
218	200	2.16	875	800	8.64
300	274	3.14	900	823	9.42
325	300	3.25	984	900	9.72
400	366	4.19	1000	914	10.47
417	385	4.36	1093	1000	10.80
433	400	4.53	1203	1100	11.88
500	457	5.24	1312	1200	12.96
541	500	5.66	1422	1300	14.04
600	549	6.28	1531	1400	15.12
656	600	6.48	1640	1500	16.20

(data is rounded to closest practical number)